

SEMiX604GB12E4s

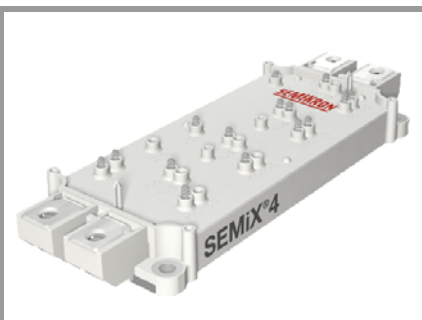

SEMiX[®]4s

Trench IGBT Modules

SEMiX604GB12E4s

Features

- Homogeneous Si
- Trench = Trenchgate technology
- $V_{CE(sat)}$ with positive temperature coefficient
- High short circuit capability
- UL recognised file no. E63532

Typical Applications

- AC inverter drives
- UPS
- Electronic Welding

Remarks

- Case temperature limited to $T_C=125^\circ\text{C}$ max.
- Product reliability results are valid for $T_j=150^\circ\text{C}$
- Dynamic values apply to the following combination of resistors:
 $R_{Gon,main} = 1,0 \Omega$
 $R_{Goff,main} = 6,2 \Omega$
 $R_{G,x} = 2,2 \Omega$
 $R_{E,x} = 0,5 \Omega$

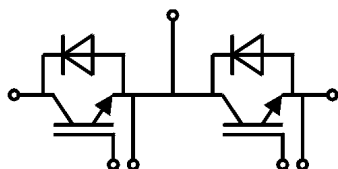

GB

Absolute Maximum Ratings

Symbol	Conditions	Values	Unit	
IGBT				
V_{CES}		1200	V	
I_C	$T_j = 175^\circ\text{C}$	$T_c = 25^\circ\text{C}$	916	A
		$T_c = 80^\circ\text{C}$	704	A
I_{Cnom}		600	A	
I_{CRM}	$I_{CRM} = 3 \times I_{Cnom}$	1800	A	
V_{GES}		-20 ... 20	V	
t_{psc}	$V_{CC} = 800\text{ V}$ $V_{GE} \leq 20\text{ V}$ $V_{CES} \leq 1200\text{ V}$	$T_j = 150^\circ\text{C}$	10	μs
T_j		-40 ... 175	$^\circ\text{C}$	
Inverse diode				
I_F	$T_j = 175^\circ\text{C}$	$T_c = 25^\circ\text{C}$	707	A
		$T_c = 80^\circ\text{C}$	529	A
I_{Fnom}		600	A	
I_{FRM}	$I_{FRM} = 3 \times I_{Fnom}$	1800	A	
I_{FSM}	$t_p = 10\text{ ms, sin } 180^\circ, T_j = 25^\circ\text{C}$	3240	A	
T_j		-40 ... 175	$^\circ\text{C}$	
Module				
$I_{t(RMS)}$		600	A	
T_{stg}		-40 ... 125	$^\circ\text{C}$	
V_{isol}	AC sinus 50Hz, $t = 1\text{ min}$	4000	V	

Characteristics

Symbol	Conditions	min.	typ.	max.	Unit
IGBT					
$V_{CE(sat)}$	$I_C = 600\text{ A}$ $V_{GE} = 15\text{ V}$ chipelevel	$T_j = 25^\circ\text{C}$	1.8	2.05	V
		$T_j = 150^\circ\text{C}$	2.2	2.4	V
V_{CE0}		$T_j = 25^\circ\text{C}$	0.8	0.9	V
		$T_j = 150^\circ\text{C}$	0.7	0.8	V
r_{CE}	$V_{GE} = 15\text{ V}$	$T_j = 25^\circ\text{C}$	1.7	1.9	$\text{m}\Omega$
		$T_j = 150^\circ\text{C}$	2.5	2.7	$\text{m}\Omega$
$V_{GE(th)}$	$V_{GE}=V_{CE}, I_C = 24\text{ mA}$	5	5.8	6.5	V
I_{CES}	$V_{GE} = 0\text{ V}$ $V_{CE} = 1200\text{ V}$	$T_j = 25^\circ\text{C}$	0.12	0.36	mA
		$T_j = 150^\circ\text{C}$			mA
C_{ies}	$V_{CE} = 25\text{ V}$ $V_{GE} = 0\text{ V}$	$f = 1\text{ MHz}$	37.2		nF
C_{oes}		$f = 1\text{ MHz}$	2.32		nF
C_{res}		$f = 1\text{ MHz}$	2.04		nF
Q_G	$V_{GE} = -8\text{ V...}+15\text{ V}$		3400		nC
R_{Gint}	$T_j = 25^\circ\text{C}$		1.25		Ω
$t_{d(on)}$	$V_{CC} = 600\text{ V}$	$T_j = 150^\circ\text{C}$	374		ns
t_r	$I_C = 600\text{ A}$	$T_j = 150^\circ\text{C}$	85		ns
		$T_j = 150^\circ\text{C}$	35		mJ
E_{on}	$R_{Gon} = 1.7\ \Omega$	$T_j = 150^\circ\text{C}$	1277		ns
$t_{d(off)}$	$R_{Goff} = 6.9\ \Omega$	$T_j = 150^\circ\text{C}$	114		ns
t_f	$di/dt_{on} = 7100\text{ A}/\mu\text{s}$	$T_j = 150^\circ\text{C}$	110.4		mJ
E_{off}	$di/dt_{off} = 6350\text{ A}/\mu\text{s}$	$T_j = 150^\circ\text{C}$			mJ
$R_{th(j-c)}$	per IGBT			0.049	K/W

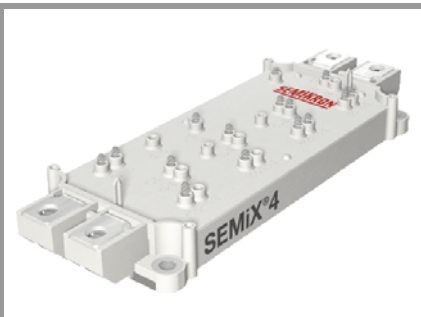

SEMiX[®]4s

Trench IGBT Modules

SEMiX604GB12E4s

Features

- Homogeneous Si
- Trench = Trenchgate technology
- $V_{CE(sat)}$ with positive temperature coefficient
- High short circuit capability
- UL recognised file no. E63532

Typical Applications

- AC inverter drives
- UPS
- Electronic Welding

Remarks

- Case temperature limited to $T_C=125^\circ\text{C}$ max.
- Product reliability results are valid for $T_j=150^\circ\text{C}$
- Dynamic values apply to the following combination of resistors:
 $R_{Gon,main} = 1,0 \Omega$
 $R_{Goff,main} = 6,2 \Omega$
 $R_{G,x} = 2,2 \Omega$
 $R_{E,x} = 0,5 \Omega$

Characteristics						
Symbol	Conditions		min.	typ.	max.	Unit
Inverse diode						
$V_F = V_{EC}$	$I_F = 600 \text{ A}$ $V_{GE} = 0 \text{ V}$ chip	$T_j = 25^\circ\text{C}$		2.1	2.46	V
		$T_j = 150^\circ\text{C}$		2.1	2.4	V
V_{F0}		$T_j = 25^\circ\text{C}$	1.1	1.3	1.5	V
		$T_j = 150^\circ\text{C}$	0.7	0.9	1.1	V
r_F		$T_j = 25^\circ\text{C}$	1.1	1.4	1.6	m Ω
		$T_j = 150^\circ\text{C}$	1.7	1.9	2.1	m Ω
I_{RRM}	$I_F = 600 \text{ A}$	$T_j = 150^\circ\text{C}$		430		A
Q_{rr}	$di/dt_{off} = 6000 \text{ A}/\mu\text{s}$ $V_{GE} = -15 \text{ V}$	$T_j = 150^\circ\text{C}$		100		μC
E_{rr}	$V_{CC} = 600 \text{ V}$	$T_j = 150^\circ\text{C}$		44		mJ
$R_{th(j-c)}$	per diode				0.086	K/W
Module						
L_{CE}				22		nH
$R_{CC'+EE'}$	res., terminal-chip	$T_C = 25^\circ\text{C}$		0.7		m Ω
		$T_C = 125^\circ\text{C}$		1		m Ω
$R_{th(c-s)}$	per module			0.03		K/W
M_s	to heat sink (M5)		3		5	Nm
M_t		to terminals (M6)	2.5		5	Nm
						Nm
w					400	g
Temperatur Sensor						
R_{100}	$T_C=100^\circ\text{C}$ ($R_{25}=5 \text{ k}\Omega$)			$493 \pm 5\%$		Ω
$B_{100/125}$	$R(T)=R_{100}\exp[B_{100/125}(1/T-1/T_{100})]$; $T[\text{K}]$;			3550 $\pm 2\%$		K

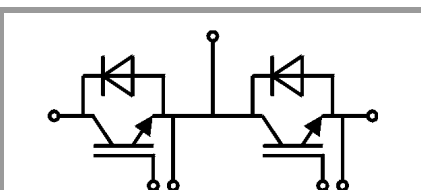

GB

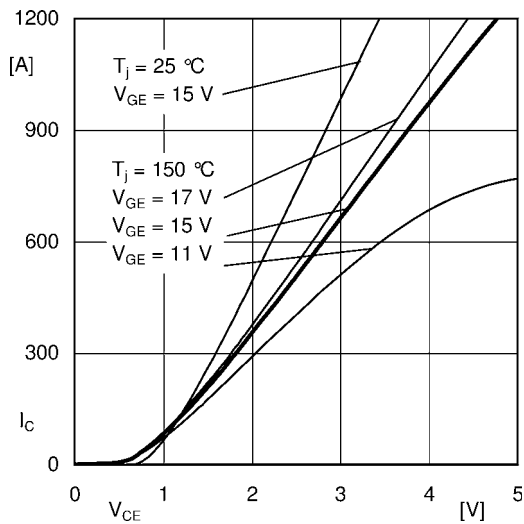

Fig. 1: Typ. output characteristic, inclusive $R_{CC'+EE'}$

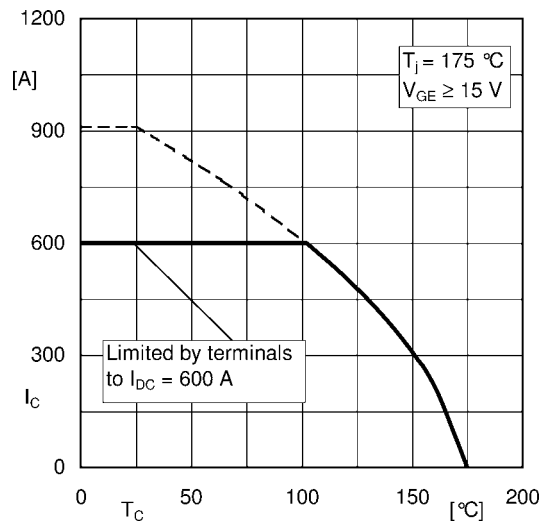

Fig. 2: Rated current vs. temperature $I_c = f(T_c)$

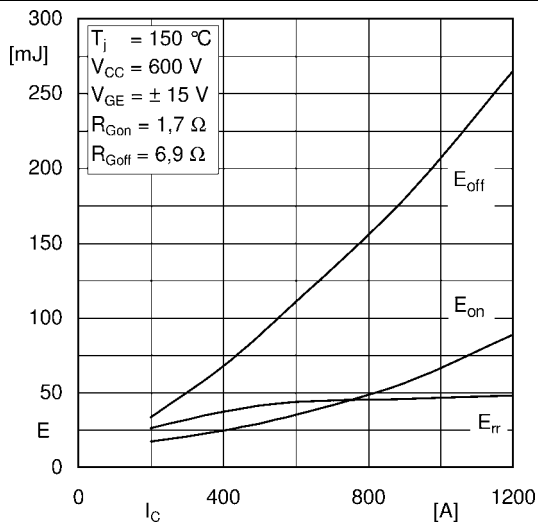

Fig. 3: Typ. turn-on /-off energy = $f(I_c)$

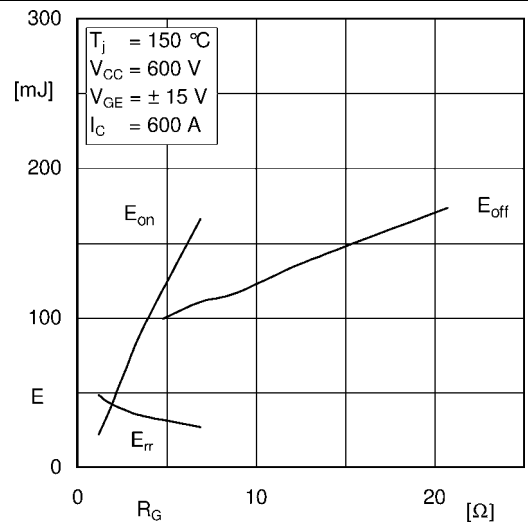

Fig. 4: Typ. turn-on /-off energy = $f(R_G)$

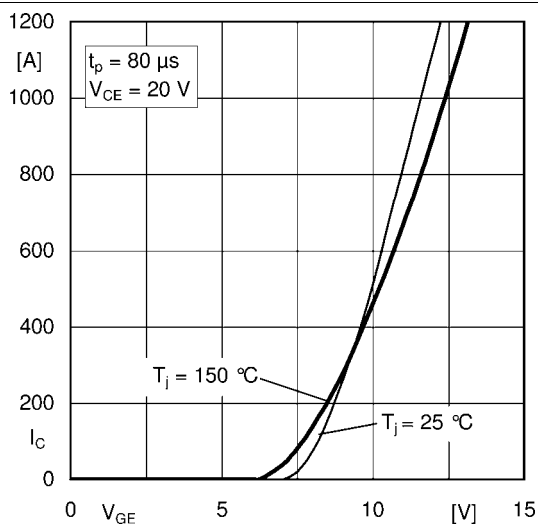

Fig. 5: Typ. transfer characteristic

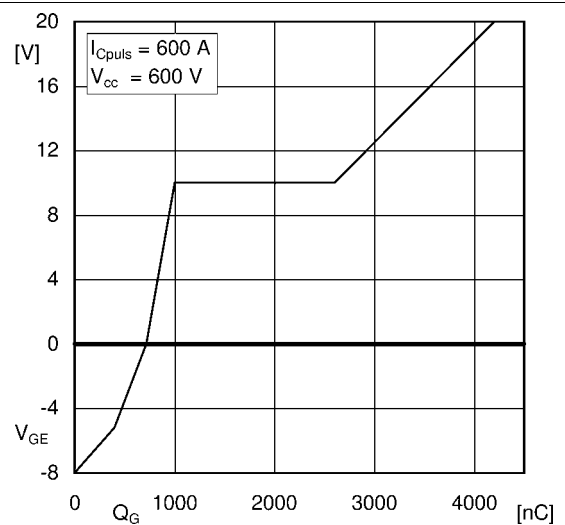

Fig. 6: Typ. gate charge characteristic

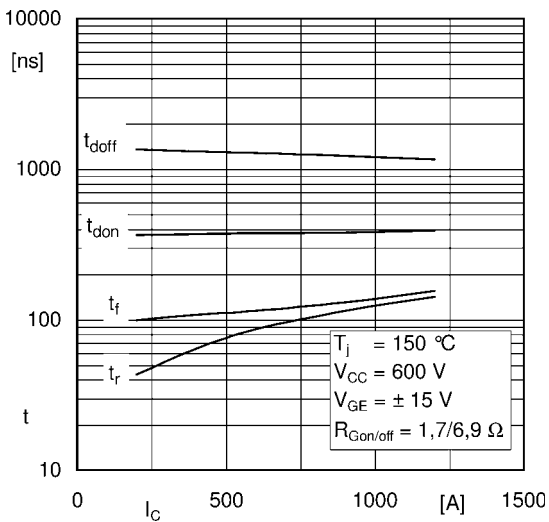

Fig. 7: Typ. switching times vs. I_C

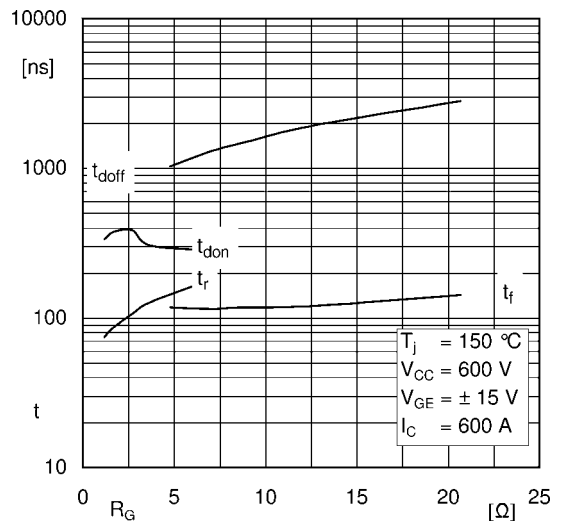

Fig. 8: Typ. switching times vs. gate resistor R_G

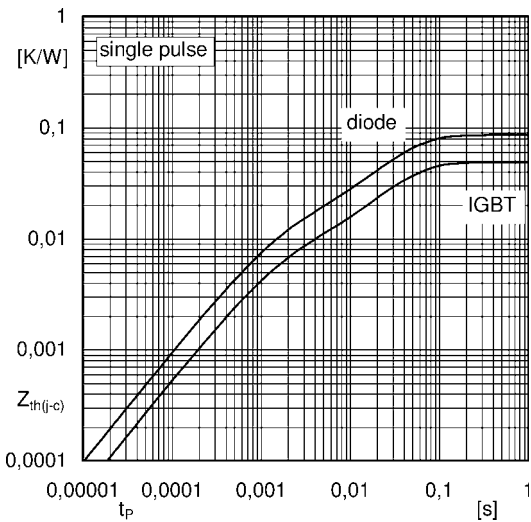

Fig. 9: Typ. transient thermal impedance

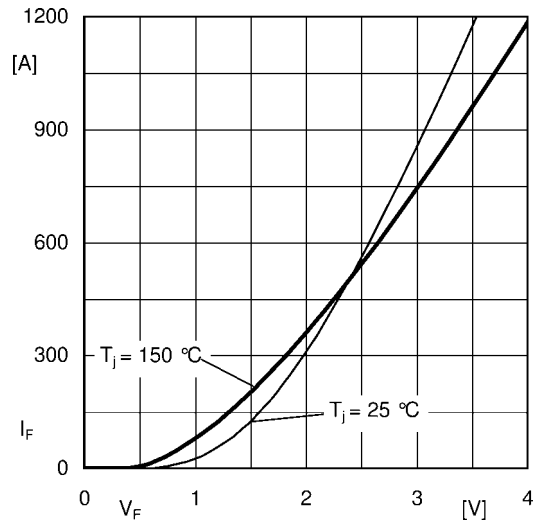

Fig. 10: Typ. CAL diode forward charact., incl. R_{CC+EE}

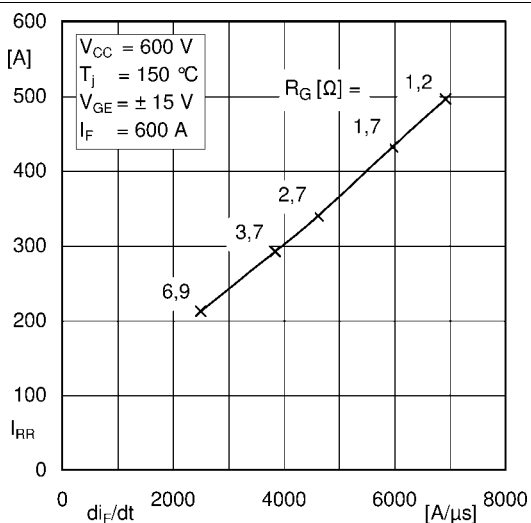

Fig. 11: Typ. CAL diode peak reverse recovery current

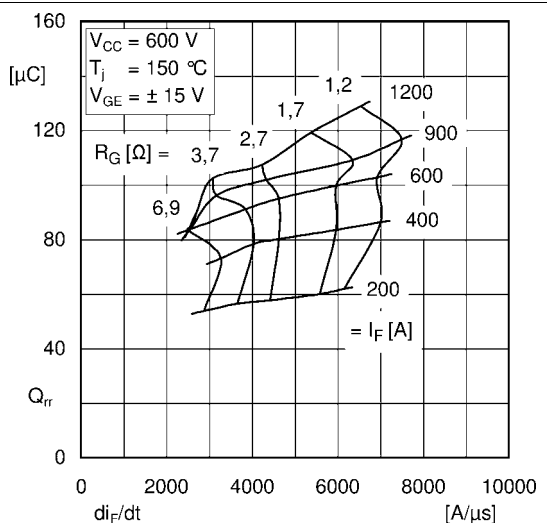
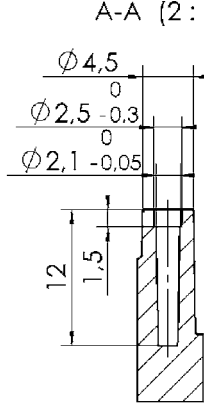

Fig. 12: Typ. CAL diode recovery charge

SEMiX604GB12E4s

case: SEMiX 4s

screw duct (4x):
A-A (2 : 1)



\square	0,3	main terminal +, - / ~, ~
//	0,2	A

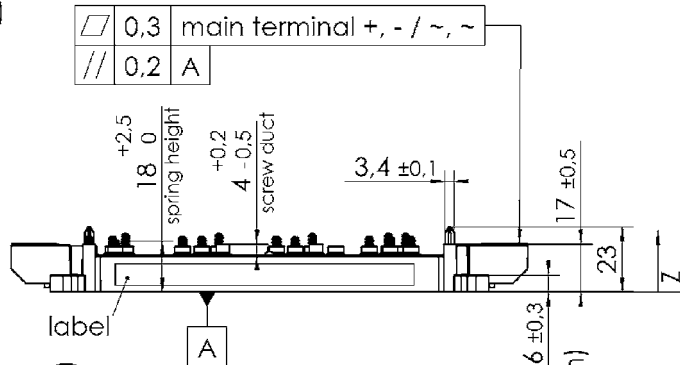

All measures in Z-direction
valid as mounted to heat sink

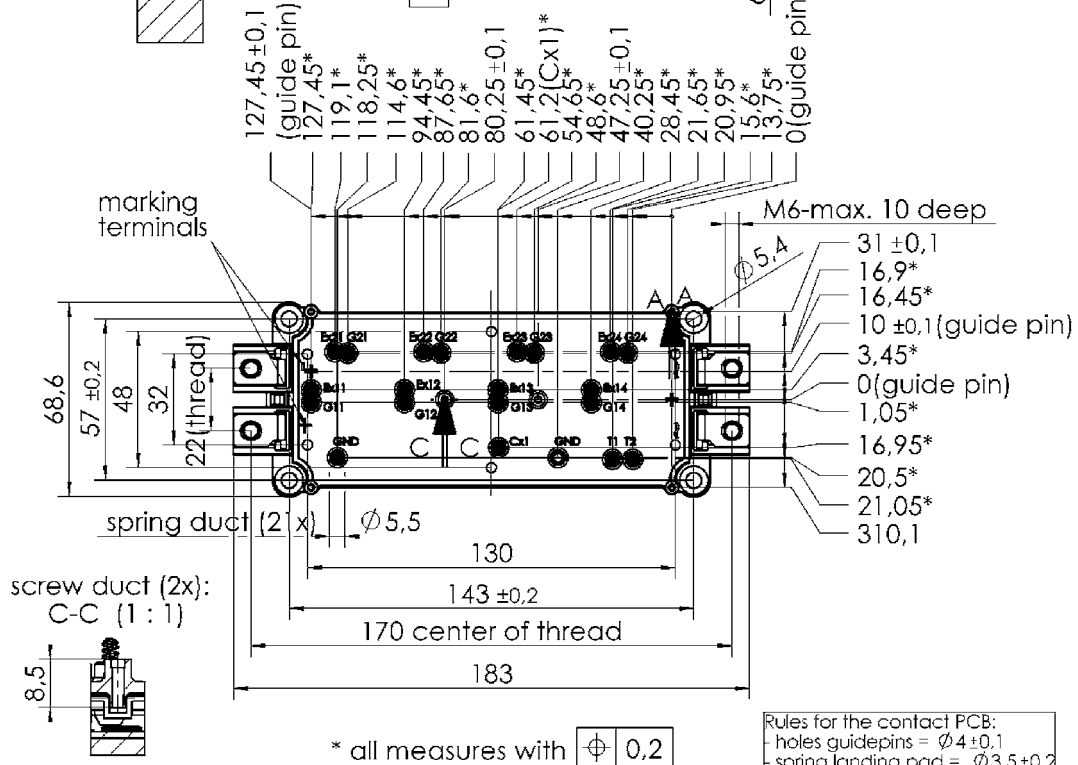

SEMiX 4s

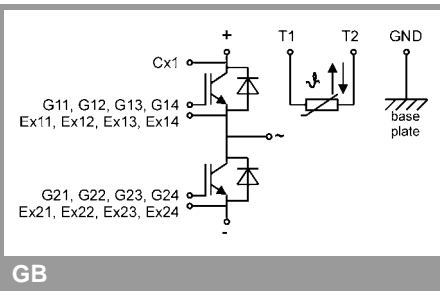

This is an electrostatic discharge sensitive device (ESDS), international standard IEC 60747-1, Chapter IX

This technical information specifies semiconductor devices but promises no characteristics. No warranty or guarantee expressed or implied is made regarding delivery, performance or suitability.